

|                                                                                                                                                                                                                                                                                                                                                                                                                                                         |                                            |                                                                                    |
|---------------------------------------------------------------------------------------------------------------------------------------------------------------------------------------------------------------------------------------------------------------------------------------------------------------------------------------------------------------------------------------------------------------------------------------------------------|--------------------------------------------|------------------------------------------------------------------------------------|
|                                                                                                                                                                                                                                                                                                                                                                        | <b>Product Specification</b>               | <b>Version</b>                                                                     |
|                                                                                                                                                                                                                                                                                                                                                                                                                                                         |                                            | <b>V1.0</b>                                                                        |
| <b>Product Type</b>                                                                                                                                                                                                                                                                                                                                                                                                                                     | <b>Infrared Laser<br/>Fixed Focus Lens</b> |  |
| <b>Product Name</b>                                                                                                                                                                                                                                                                                                                                                                                                                                     | <b>IR-850-1W-D15</b>                       |                                                                                    |
| <b>Product Number</b>                                                                                                                                                                                                                                                                                                                                                                                                                                   | <b>R10030003</b>                           |                                                                                    |
| <b>Product Size</b>                                                                                                                                                                                                                                                                                                                                                                                                                                     | <b>D*H=Φ12*9.2mm</b>                       |                                                                                    |
| <b>Application Range:</b><br>Safe city, large-scale factory, intelligent transportation, on-board system, airport port, oil depot, security department, prison, water conservancy and electric power, energy mining, ecological protection, administrative law enforcement, fishery and sea surveillance, border defense and other night vision monitoring fill light.                                                                                  |                                            |                                                                                    |
| <b>Statement:</b><br>This specification is copyrighted by 3KM Optoelectronics Technology Co., Ltd. and may not be distributed to employees who are 3KM away without the written approval of the 3KM. It may not be used, copied or modified in whole or in part, and may not be disclosed in any way. 3KM reserve the right to update the technical parameters of the product to ensure that the latest and best products are provided to the customer. |                                            |                                                                                    |
| <b>3KM Optoelectronics Technology Co., Ltd.</b>                                                                                                                                                                                                                                                                                                                                                                                                         |                                            | File Type: Specification                                                           |
| <b>Prepared</b>                                                                                                                                                                                                                                                                                                                                                                                                                                         | LGN                                        | Sep 29, 2019                                                                       |
| <b>Review</b>                                                                                                                                                                                                                                                                                                                                                                                                                                           | LZHJ                                       | Sep30, 2019                                                                        |
| <b>Approve</b>                                                                                                                                                                                                                                                                                                                                                                                                                                          | WYM                                        | Sep30, 2019                                                                        |

| Parameters                  |                                    |
|-----------------------------|------------------------------------|
| Item                        | Parameters                         |
| Size                        | D*H: 12mm*9.2mm                    |
| Applicable Wavelength Range | 800nm~980nm                        |
| Illumination Angle          | 15°(@ 20%) 17° (1/e <sup>2</sup> ) |
| Material                    | Polycarb                           |
| Applicable LightSource      | IR-850-1W-3838 (3KM VCSEL)         |
| Storage Temperature         | -50°C~+100°C                       |
| Operating Temperature       | -40°C~+85°C                        |
| Environmental Standards     | (EU)2015/863                       |

Product Size

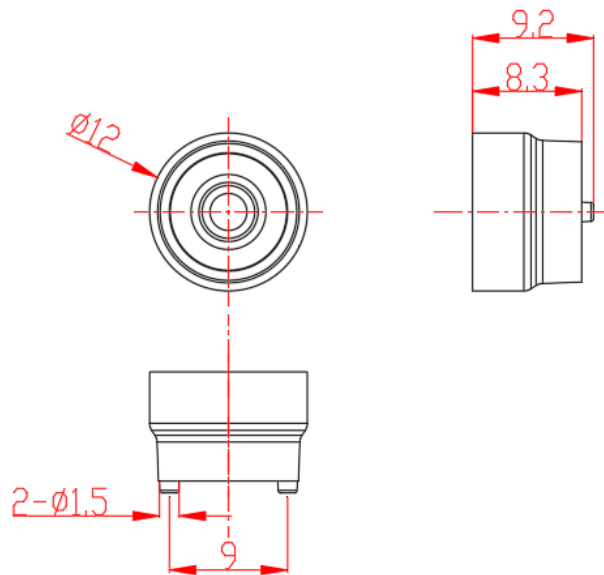

unit: mm

Optical Angle

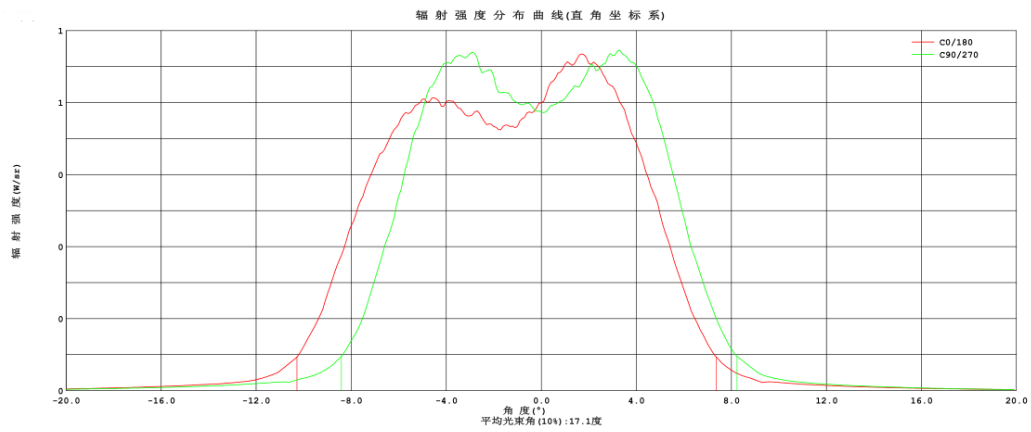

Contact Information

|                  |                                                                                                                           |
|------------------|---------------------------------------------------------------------------------------------------------------------------|
| Company Name:    | 3KM Optoelectronics Technology Co., Ltd.                                                                                  |
| Business Phone:  | +86-0755-6686 4401                                                                                                        |
| Company website: | www.sz3km.cn                                                                                                              |
| Email:           | sales@sz3km.com                                                                                                           |
| Address:         | 12F, Building 1, Heng Changrong Hi-Tech Park, No. 128 Shangnan East Road, Xinqiao Street, Baoan District, Shenzhen, P.R.C |